

MOSTEC AG
Elektronische Mess- und Regelsysteme
CH-4410 Liestal, Switzerland
TEL. +41 61 921 40 90
FAX +41 61 921 40 83
Internet: www.mostec.ch
E-Mail: info@mostec.ch

MOSTEC



Operating Manual

Conductivity meter

M2136

Warranty

Mostec warrants this product to be free of manufacturing defects for a 2-year period after the original date of purchase. Within this period, defective products will be repaired free of charge provided that the defect occurred during normal operation. This warranty does not cover damage to the product resulting from ordinary usage such as front panel scratches, broken control elements and corrosion, etc. The customer is responsible for shipping and packing charges for products returned under warranty to Mostec. Mostec warrants this product beyond the 2-year warranty period for an additional 2 years in case of long term damages due to improper manufacturing. Such damages as poorly soldered joints or other assembly problems are also covered by the warranty. Transportation damages are not covered by the warranty and should be referred to the respective delivery service.

Technical description

The M2136 conductivity meter is suitable for water, waste water or pure water conditioning in continuous or batch-type operating modes, for liquid chromatography or for general chemical process monitoring. Temperature coefficient of the cell is compensated either manually or automatically by an external Pt-100 platinum probe within the range of 0°C to 120°C.

Commercially available conductivity cells K-factor is 0.01, 0.1, 1.0 and 10 cover a dynamic range from 0.01µS to 200mS full scale. An internal synchronous rectifier eliminates the capacitive error currents induced by the cell cable.

The ranges conductivity and temperature have an optional signal current output of 0...20mA. An external 24V-signal switches the output to conductivity or temperature.

Two floating limit or alarm contacts can be set over the entire range. Each is defined as a normally open or as a normally closed contact.

Supply lines and all other lines, either from or to the conductivity meter, are protected by internal noise limiters against HF-noise.

Power supply: Universal supply 20 to 253VAC/DC

Index:	Page
A. Front panel controls	3
B. How to change the measurement range - cell's K-factor / handling access codes	3
C. How to adjust the limit contacts	4
D. How to change the temperature compensation to Pt100	4
E. How to change the temperature compensation to manual	5
F. How to change the temperature slope %/°C	5
G. How to change the cell correction factor	6
H. How to change the signal current output	6
J. User menu	7
K. Technical data	8

A. Front panel controls

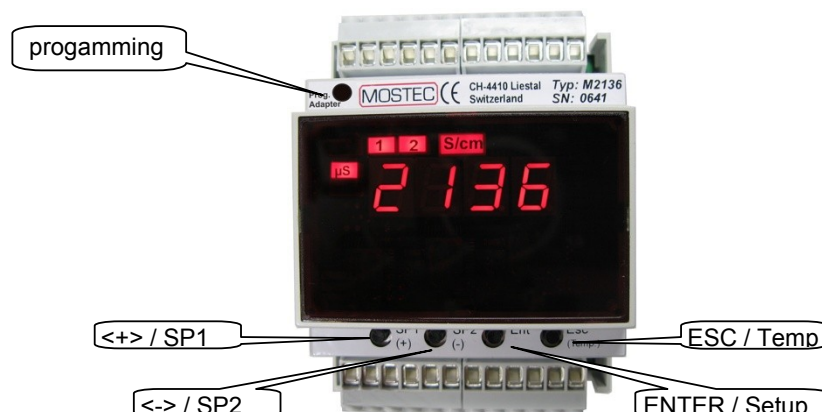

B. How to change the measurement range / cell's K-factor

The measurement range is indicated by two red LED lamps (μS or mS). Possible cell K-factors are $C=0.01$, $C=0.1$, $C=1.0$ and $C=10$ in the measurement ranges $0\dots2\mu\text{S}$, $0\dots20\mu\text{S}$, $0\dots200\mu\text{S}$, $0\dots2000\mu\text{S}$, $0\dots20\text{mS}$ and $0\dots200\text{mS}$.

1. Push and hold the button <ENTER>.
 - ⇒ The display is flashing between the actual value and SELC.
 - ⇒ After 5 seconds, the display will show up the program menu SELEC.
2. press <ENTER>
 - ⇒ The display shows the actual value of the measurement range.
3. Change the value for the measurement range by the button <+> or <->, then press <ENTER>.
 - 2 = C 0.01 M 20 μS (C = cell K-factor, M = measurement range)
 - 3 = C 0.01 M 2 μS
 - 9 = C 0.1 M 200 μS
 - 10 = C 0.1 M 20 μS
 - 11 = C 0.1 M 2 μS
 - 16 = C 1.0 M 2000 μS
 - 17 = C 1.0 M 200 μS
 - 18 = C 1.0 M 20 μS
 - 22 = C 1.0 M 20mS
 - 25 = C 1.0 M 200mS
4. Press button <ESC>
 - ⇒ the display shows the actual value.

1. Unlock the user menu / insert or modify the menu protection access code:

The values of the user menu can be protected from unintended access using an access code. After activating the access code, menu values can be observed but no longer modified. To modify setpoints and other parameters, the access code has to be set to the value 0. If the code has a value different from 0, writing to the user menu is suppressed.

Set the access code:

1. Press and hold both button <ENTER> for 4 seconds.
 - ⇒ After 4 seconds The display shows *SELC* indicating the user menu.
2. Now navigate to the *CODE* menu item with the button <->, then press <ENTER>.
 - a) A code has already been entered:* The display flashes between Code and 0. Enter now the valid access code with the buttons <+> and <-> and confirm with the <ENTER> key. If the code is wrong, the instrument quits the user menu (in case you do not know your code any more, call MOSTEC we have a unlock code). If the code is correct, it can be modified with the keys <+> and <->, or in order to make changes to the user menu, set to 0.
 - b) No code has been entered:* The display shows 0. A code can be entered with the keys <+> and <-> then confirm with the <ENTER> key. If you do not need the user menu protection, leave the value 0 unchanged and quit the code menu with the <ESC> key.

C. How to adjust the limit contacts

1. Unlock the user menu / insert or modify the menu protection access code:

see B, page 3

2. Adjust the limit contacts

Both limit contacts are identical and are therefore adjusted in the same way. The status of the limit contacts is indicated by two red lamps. Push the button <+ / SP1> displays the value for limit contact #1, button <- / SP2> the limit contact #2.

1. Push and hold the button <ENTER>.
 - ⇒ The display is flashing between the actual value and *SELC*.
 - ⇒ After 4 seconds, the display will show up the program menu *SELC*.
2. Change to menu *SP_1* for limit contact #1 or *SP_2* for limit contact #2, by the button <+> or <->, then press <ENTER>.
 - ⇒ The display shows the actual value of the limit contact.
3. Change the value for the limit contact by the button <+> or <->, then press <ENTER>.
4. Change to menu *LEd_1* for limit contact #1 or *LEd_2* for limit contact #2, by the button <+> or <->, then press <ENTER>.
5. Change the lamp status by the button <+> or <->, then press <ENTER>.
 - "nor": LED lamp ON, when input > setpoint
 - "Inr": LED lamp ON, when input < setpoint
6. Change to menu *rEL_1* for limit contact #1 or *rEL_2* for limit contact #2, by the button <+> or <->, then press <ENTER>.
7. Change relay operating mode by the button <+> or <->, then press <ENTER>.
 - "nor": Relay ON, when input > setpoint (normally open contact closed)
 - "Inr": Relay ON, when input < setpoint (normally open contact open)
8. Press button <ESC>
 - ⇒ the display shows the actual value.

Note: Only for changing the limit value, points 4...7 aren't necessary.

D. How to change the temperature compensation to Pt100

The temperature compensation is set to Pt-100 sensor, the LED lamp Pt-100 is on.

Push the button <ESC / Temp> to display the actual temperature.

If the M2136 is set to Pt100 and the Pt100 sensor is not connected, damaged, or the temperature is higher than 135°C, the processor internally uses a temperature value of 25°C and the lamp Pt-100 is flashing.

1. Unlock the user menu / insert or modify the menu protection access code:

see B, page 3

2. Change the temperature compensation to Pt100

1. Push and hold the button <ENTER>.
 - ⇒ The display is flashing between the actual value and *SELC*.
 - ⇒ After 4 seconds, the display will show up the program menu *SELC*.
2. Change to menu *TEPR* by the button <+> or <->, then press <ENTER>.
3. Change the value to *P100* by the button <+> or <->, then press <ENTER>.
4. Press button <ESC>
 - ⇒ the display shows the actual value.

E. How to change the temperature compensation to manual

The temperature compensation is set to manual, the lamp Pt-100 is off.
Push the button <ESC/Temp> to display the actual temperature.

1. Unlock the user menu / insert or modify the menu protection access code:

see B, page 3

2. Change the temperature compensation to manual

1. Push and hold the button <ENTER>.
⇒ The display is flashing between the actual value and *SELC*.
⇒ After 4 seconds, the display will show up the program menu *SELEC*.
2. Change to menu *T_HR* by the button <+> or <->, then press <ENTER>.
⇒ The display shows the actual value of the manual temperature.
3. Change the value for the temperature by the button <+> or <->, then press <ENTER>.
4. Change to menu *TEPR* by the button <+> or <->, then press <ENTER>.
3. Change the value to *HAND* by the button <+> or <->, then press <ENTER>.
4. Press button <ESC>
⇒ the display shows the actual value.

F. How to change the temperature slope %/°C

All liquids have a positive temperature coefficient, expressed in %/°C conductivity change. The higher the temperature the lower the electrical resistance which is equal to higher siemens values. Water has a slope of about +2.25%/°C. The temperature slope should be set in such a way, to display a constant conductivity value when the temperature only changes.

Example:

The conductivity is 15.5µS at a temperature of 20°C. Now increase the temperature to 30°C, without chemically changing the medium. The conductivity must still show 15.5µS. When the displayed conductivity value changes, the temperature slope requires readjustment.

Measuring the absolute conductivity at 25°C:

You may switch off the temperature compensation by simply selecting slope 0.0%/°C. The indicated values are now not temperature compensated.

1. Unlock the user menu / insert or modify the menu protection access code:

see B, page 3

2. Change the temperature slope %/°C

1. Push and hold the button <ENTER>.
⇒ The display is flashing between the actual value and *SELC*.
⇒ After 5 seconds, the display will show up the program menu *SELEC*.
2. Change to menu *SLPE* by the button <+> or <->, then press <ENTER>.
⇒ The display shows the actual value of the temperature slope.
3. Change the value for the temperature slope by the button <+> or <->, then press <ENTER>.
4. Press button <ESC>
⇒ the display shows the actual value.

G. How to change the cell correction factor

If the conductivity cell has a special K-factor outside of $K=1.0$, $K=0.1$ and $K=0.01$, the value can be adjusted with the cell correction factor.

Factory set value of K is 1.000. If you have to change this value, the calibration of the M2136 is maintained, but the displayed conductivity value is no longer the standard calibration.

1. Unlock the user menu / insert or modify the menu protection access code:

see B, page 3

2. Change the cell correction factor

1. Push and hold the button <ENTER>.
 - ⇒ The display is flashing between the actual value and *SELC*.
 - ⇒ After 4 seconds, the display will show up the program menu *SELC*.
2. Change to menu *GAIN* by the button <+> or <->, then press <ENTER>.
 - ⇒ The display shows the actual value of cell correction factor.
3. Change the value for the correction factor by the button <+> or <->, then press <ENTER>.
4. Press button <ESC>
 - ⇒ the display shows the actual value.

H. How to change the signal current output

An external signal switches the current output from conductivity to temperature.

- ⇒ clamps 14 & 15 are open: the output current reflects conductivity
- ⇒ clamps 14 & 15 are closed: the output current reflects 0...130°C

1. Unlock the user menu / insert or modify the menu protection access code:

see B, page 3

2. Change the signal current output minimum

The signal current output is always the same for all measurement ranges.

1. Push and hold the button <ENTER>.
 - ⇒ The display is flashing between the actual value and *SELC*.
 - ⇒ After 4 seconds, the display will show up the program menu *SELC*.
2. Change to menu *I₀* by the button <+> or <->, then press <ENTER>.
3. Change the value for signal current output by the button.
 - For example: The output current must be 4.00mA at 0.00µS → adjust the value to 4.00
4. Press button <ESC>
 - ⇒ the display shows the actual value.

3. Change the signal current output maximum

The signal current output is always the same for all measurement ranges.

1. Push and hold the button <ENTER>.
 - ⇒ The display is flashing between the actual value and *SELC*.
 - ⇒ After 4 seconds, the display will show up the program menu *SELC*.
2. Change to menu *I_{GR}* by the button <+> or <->, then press <ENTER>.
3. Change the value for signal current output by the button.
 - For example: The output current must be 20.00mA at 20.00µS → adjust the value to 20.00
4. Press button <ESC>
 - ⇒ the display shows the actual value.

K. User menu

Menu access: press the button **(ENT)** for 4 seconds.

Navigation within the menu: buttons **(+)** and **(-)**

Select a menu item: button **(ENT)** (= ENTER)

Leave a menu item: button **(ESC)** (= ESCAPE)

Change a value: buttons **(+)** and **(-)**

(ENT) & **(ESC)**

↓ → <i>SELC</i>	(ENT) → ← (ESC) / (ENT) ** *	(+) / (-) <i>22</i>	Adjust measuring range
↓ (+) / ↑ (-) → <i>T_HR</i>	(ENT) → ← (ESC) / (ENT)	(+) / (-) <i>25.7</i>	Adjust hand temperature
↓ (+) / ↑ (-) → <i>TEPR</i>	(ENT) → ← (ESC) / (ENT)	(+) / (-) <i>PT100 / HAND</i>	Set to Pt-100 or manual
↓ (+Ta) / ↑ (-) → <i>SLPE</i>	(ENT) → ← (ESC) / (ENT)	(+) / (-) <i>2.25</i>	Adjust slope
↓ (+) / ↑ (-) → <i>GAIN</i>	(ENT) → ← (ESC) / (ENT)	(+) / (-) <i>1.053</i>	Adjust gain
↓ (+) / ↑ (-) → <i>SP1</i>	(ENT) → ← (ESC) / (ENT)	(+) / (-) <i>10.00</i>	Adjust setpoint 1
↓ (+) / ↑ (-) → <i>LED1</i>	(ENT) → ← (ESC) / (ENT)	(+) / (-) <i>NOR / INR</i>	LED 1 function normal/inverse
↓ (+) / ↑ (-) → <i>REL1</i>	(ENT) → ← (ESC) / (ENT)	(+) / (-) <i>NOR / INR</i>	Relay 1 normal/inverse
↓ (+) / ↑ (-) → <i>SP2</i>	(ENT) → ← (ESC) / (ENT)	(+) / (-) <i>10.00</i>	Adjust setpoint 2
↓ (+) / ↑ (-) → <i>LED2</i>	(ENT) → ← (ESC) / (ENT)	(+) / (-) <i>NOR / INR</i>	LED 2 function normal/inverse
↓ (+) / ↑ (-) → <i>REL2</i>	(ENT) → ← (ESC) / (ENT)	(+) / (-) <i>NOR / INR</i>	Relay 2 normal/inverse
↓ (+) / ↑ (-) → <i>I_0</i>	(ENT) → ← (ESC) / (ENT)	(+) / (-) <i>4.00</i>	Adjust output current minimum
↓ (+) / ↑ (-) → <i>I_GA</i>	(ENT) → ← (ESC) / (ENT)	(+) / (-) <i>20.00</i>	Adjust output current maximum
↓ (+) / ↑ (-) → <i>CODE</i>	(ENT) → ← (ESC) / (ENT)	(+) / (-) <i>0036</i>	Change menu access code

** Leave the menu without saving the value

* Leave the menu and save the value

J. Technical Data

Measuring ranges:	0...2.000µS (K=0.1, K=0.01) 0...20.00µS (K=1.0, K=0.1, K=0.01) 0...200.0µS (K=1.0, K=0.1, K=0.01) 0...2.000mS (K=1.0, K=0.1) 0...20.00mS (K=1.0) 0...200.0mS (K=10.0)
Range display:	2 red LED-Lamps
Display:	Red LED-display 4-digit, character high 10mm
Accuracy:	0.5%
Reproducibility:	<0.2%
Measuring frequency:	80Hz and 10kHz
Measuring amplitude:	70/150mV, conductive cell only
Step response:	Time between a conductivity change from 0% to 100% or reverse measured between 10% and 90% = 4 seconds.
Input protection:	virtual zero, protected by diodes
Temperature compensation:	manual form 0 to 120°C, automatic by an external Pt-100 platinum sensor, 2 or 3-wire. The unit calculates with 25°C when the Pt-100 sensor wires are broken. 0.00%/°C (=without compensation) to 8.00%/°C.
Temperature slope:	The unit calculates with 25°C when the Pt-100 sensor wires are broken.
Conductivity of water:	The conductivity of water is measured and temperature compensated.
Reference temperature:	25°C
Maximum length of cell cable:	Cable capacity is compensated automatically. The max. capacity must be <0.02µF.
Limit contacts:	Two floating change-over contacts may be adjusted over the full range. Each can be defined as a normally open or normally closed contact by an internal slide switch.
Status:	two red LED-Lamps
Hysteresis:	adjustable, the factory setting is ±5 digit
Contacts rating:	1A with resistive load / 230VAC
Contact life:	100'000 operations at max. load 10'000'000 operation mechanically, without load
Option current output:	programmable in the range of 0...20mA, galvanically isolated By a external 24V signal, the current output can be switched between conductivity- and temperature measuring. Conductivity measuring (terminal 14 & 15 open): Current output in depending of conductivity measuring Temperature measuring (terminal 14=0V, 15=24V): Current output in depending of temperature measuring
Max. load:	500Ω
Output impedance:	>1MΩ typical
Device settings:	with bush buttons behind the front panel, see operating manual
change options:	measuring ranges, cells K-factor, temperature slope, temperature, limit contacts: operating mode, hysteresis, status of the LED-Lamps
Power supply:	20 to 253VAC or DC
Power supply load:	4.5 to 7.0W at 230VAC
CE-conformity:	fulfilled
Terminals:	3 x 6-pole plug-in screw terminals
Terminal description:	1 = supply voltage: AC~/DC(+) 2 = supply voltage: AC~/DC(-) 3 = supply voltage: PE 4 = signal output PE 5 = signal output (+) 6 = signal output (-) 7 = alarm contact 1, c.o. contact 8 = alarm contact 1, n.c. contact 9 = alarm contact 1, n.o. contact 10 = alarm contact 1, c.o. contact 11 = alarm contact 2, n.c. contact 12 = alarm contact 2, n.o. contact 13 = alarm contact 2, c.o. contact 14 = Switch signal for current output (+24V) 15 = Switch signal for current output (0V) 19 = Pt-100 sensor + 20 = Pt-100 sensor - 21 = Pt-100 sensor sense - 22 = conductivity cell PE 23 = conductivity cell + 24 = conductivity cell -
c.o.= change over	
n.o.= normally open	
d.c.= normally closed	
Mounting:	35mm mounting rail, EN50022-35
Weight:	200g
Warranty:	2 years
Options:	- conductivity cell type M8836s and M8836si - customer specified functions

M2136 Menu Diagramm:

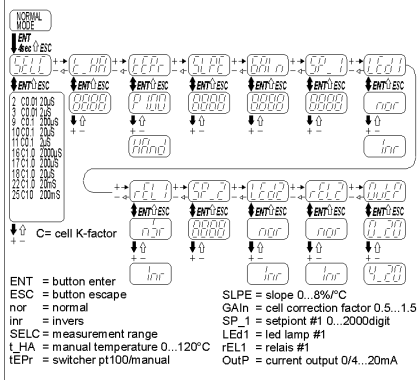

Dimensions (mm):

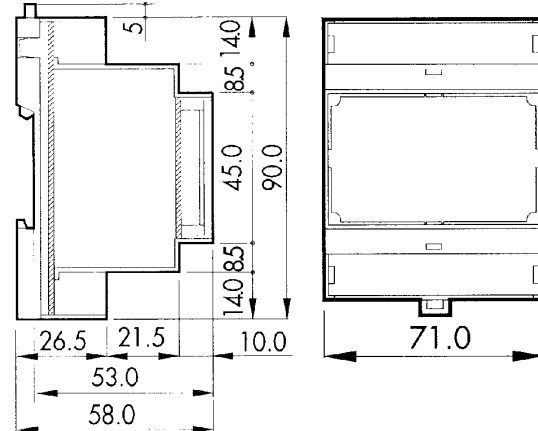

Cell connecting diagram :

