

Mostec AG
Mess- und Regeltechnik
Lausenerstrasse 13a
CH-4410 Liestal
Switzerland
Tel. +41 61 921 40 90
Fax +41 61 921 40 83
Internet www.mostec.ch
E-Mail info@mostec.ch

MOSTEC

Alarm Unit Type M2118



Technical description

The alarm unit M2118 is used to check or control any type of signal current or voltage signal. It converts the input signal to an internal standard signal of for example 0 to 100.0%. In this range two alarm contacts can be set independently. A 4-digit LED display shows the actual value and setpoints or alarm values in the range of -1999 to 9999 units.

All settings as alarm values, hysteresis, range and operating mode of the floating contacts can be set with a link cable, connected to a personal computer or a laptop.

Both alarm contacts can also be programmed with tiny push button switches.

A typical application would be to measure and monitor pressure in a process vessel. The pressure transmitter converts the pressure of 1 to 10 bar to a current signal of 4 to 20mA. The M2118 monitors under and overpressure in the vessel. It converts the 4... 20mA signal current to 0...100.0%. The alarm is set between 0% (=1 bar) and 100.0% (=10 bar). With these floating alarm contacts, overpressure valves, compressors, etc. are driven directly.

Optionally, a galvanic isolated output signal of 0...20mA or 4...20mA is available.

Power supply:

Universal supply 20 to 253VAC/DC

Technical Data:

Input signal:	0/4...20mA/0...1V and 10V, programmable	
Input load / impedance:	current signal=51Ω, voltage signal=1MΩ	
2-Wire transmitter supply:	24VDC max. 25mA	
Display:	4-digit, LED red, 10mm	
Display range:	-1999...9999	
Accuracy:	±0.1% at 23°C ambient temperature	
Reproducibility:	±0.1%	
Temperature coefficient:	zero drift: 30ppM/°C typical, gain drift: 25ppM/°C typical	
Long-term stability:	±0.1%	
Working temperature range:	-5 to +45°C	
Maximum humidity:	95%, non-condensing	
Range adjustment:	by computer programmable, see manual	
Zero-/Gain adjustment:	by computer programmable, see manual	
Alarm contacts:	two, adjustable between 0,0 and 100,0%	
Hysteresis:	by computer programmable, factory set: ±5 digit, see manual	
Contacts:	floating change over contacts	
Max. contact load:	1A/230V resistive	
Change alarm contacts:	by button switches or computer programmable, see manual	
Display alarm contacts:	by button switches or computer programmable, see manual	
Mode of the alarm contacts:	with two red LED-Lamps	
Display unit:	with one red LED-Lamp	
Option current output:	0/4...20mA, galvanically isolated	
Max. load:	500Ω	
Output impedance:	>1MΩ typical	
Power supply:	20 to 253VAC or DC	
Power supply load:	4.5 to 7.0W at 230VAC	
CE-conformity:	fulfilled	
Terminals:	3 x 6-pole plug-in screw terminals	
Terminal description:	1 = supply voltage: AC~/DC(+)	2 = supply voltage: AC~/DC(-)
	3 = supply voltage: PE	4 = signal output PE
	5 = signal output (+)	6 = signal output (-)
	7 = alarm contact 1, c.o. contact	8 = alarm contact 1, n.c. contact
	9 = alarm contact 1, n.o. contact	10 = alarm contact 1, c.o. contact
	11 = alarm contact 2, n.c. contact	12 = alarm contact 2, n.o. contact
	13 = signal input PE	14 = signal input (-)
	15 = signal input current (+)	16 = signal input voltage (+)
	17 = 2-Wire transmitter supply +24V	18 = 2-Wire transmitter supply PE
	35mm mounting rail, EN50022-35	
Weight:	200g	
Warranty:	2 years	
Options:	- Link cable for programming with a computer: P/N M2029LAP - Programming software (free download: www.mostec.ch) - Other input signal	
How to order:	M2118, input 4...20mA, display 50...100,0%, SP1=2,00bar, SP2=9,50bar, Hysteresis ±2digit, current output: 50...100,0% = 0...20mA	

c.o. = change over
n.o. = normally open
n.c. = normally closed

Pressure control:

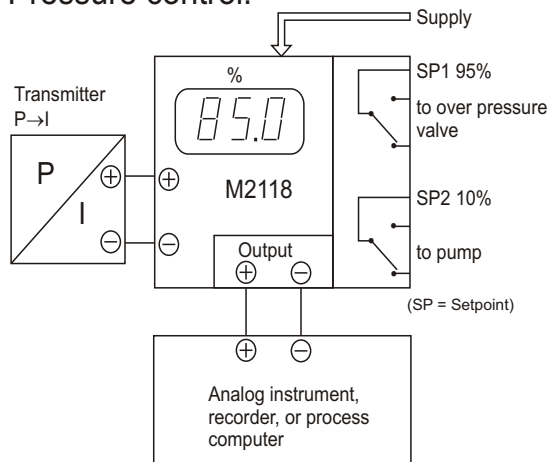

Dimensions (mm):

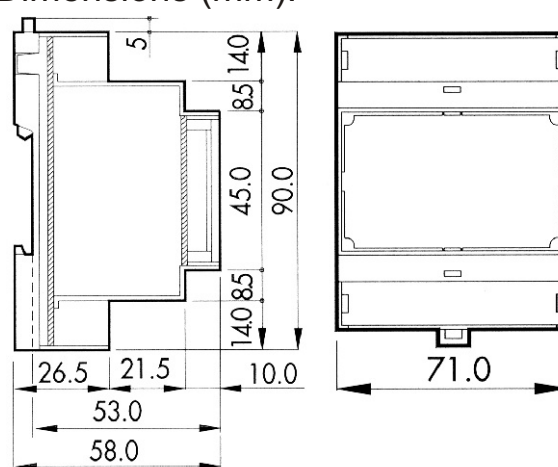

MOSTEC

Mess- und Regeltechnik
Lausenerstrasse 13a
CH-4410 Liestal
Switzerland
Tel. +41 61 9214090
Fax +41 61 9214083

